

Omega™

Glanded pumps.
Tørløber pumper.
Trockenläufer Pumpen.

In-line DN 32

Omega 3-100-2 (D)

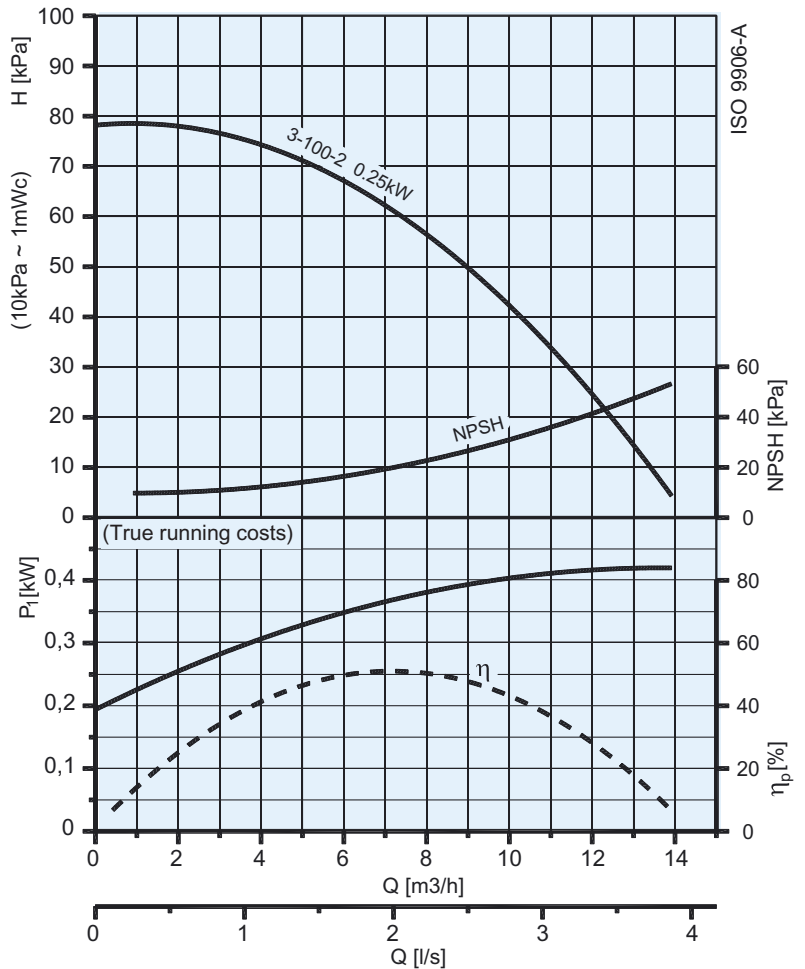
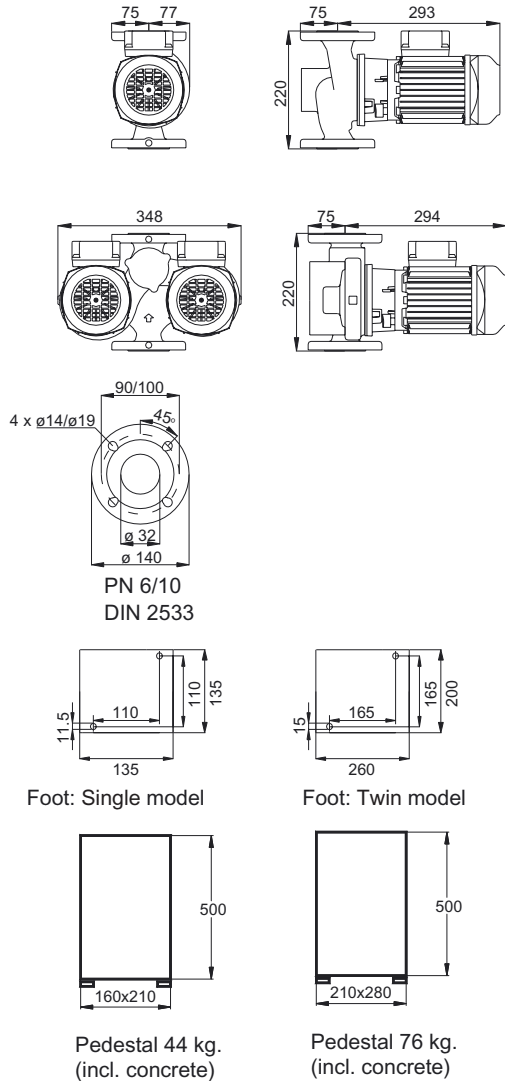

P_1 :
True running costs
Optagen effekt
Leistungsaufnahme

$$P_3 = Q \times H = \eta_p \times P_2$$

$$P_2 = \eta_m \times P_1$$

Type.	Kg		Motor P_2 (kW)	In (A) (50Hz) standard			Cos ϕ	n (min ⁻¹)	dB(A)	η_m (%) standard.		
	Single	Twin		1x230V	3x400/230V	3x690/400V				eff 1	eff 2	eff 3
Omega 3-100-2 (D)	14,9	-	0,25	-	0,8/1,39	-	0,70	2880	46	73	67	-
Omega 3-100-2 (D)	15,5	-	0,25	1,9	-	-	0,98	2770	46	-	67	62

D = Twin pump

IEC 38 +/- 10%, 50 Hz, IP 55

This model is also available as an Omega-Drive - a selfregulating pump with integral inverter and optional differential pressure transducer. Denne model fås også som Omega-Drive - en selvregulerende pumpe med integreret frekvensomformer med eller uden monteret differensstryk-transmitter. Dieses Model ist auch als Omega-Drive lieferbar - eine selbstregulierende Pumpe mit integriertem Umrichter, mit montiertem oder ohne Differenzdruckschalter.

Smedegaard reserve the right to change the product without prior notice and take no responsibility for inaccuracies or misprints.